

LMV7235/LMV7239/LMV7239Q 75 nsec, Ultra Low Power, Low Voltage, Rail-to-Rail Input Comparator with Open-Drain/Push-Pull Output

Check for Samples: [LMV7235](#), [LMV7239](#)

FEATURES

- ($V_S = 5V$, $T_A = 25^\circ C$)
- Typical values unless otherwise specified)
- Propagation delay 75 nsec
- Low supply current 65 μA
- Rail-to-Rail input
- Open drain and push-pull output
- Ideal for 2.7V and 5V single supply applications
- Available in space saving packages
 - 5-pin SOT-23
 - 5-pin SC70
- LMV7239Q is an automotive grade product that is AECQ grade 1 qualified and is manufactured on an automotive grade flow.

APPLICATIONS

- Portable and battery powered systems
- Scanners
- Set top boxes
- High speed differential line receiver
- Window comparators
- Zero-crossing detectors
- High speed sampling circuits
- Automotive

DESCRIPTION

The LMV7235/LMV7239/LMV7239Q are ultra low power, low voltage, 75 nsec comparators. They are guaranteed to operate over the full supply voltage range of 2.7V to 5.5V. These devices achieve a 75 nsec propagation delay while consuming only 65 μA of supply current at 5V.

The LMV7235/LMV7239/LMV7239Q have a greater than rail-to-rail common mode voltage range. The input common mode voltage range extends 200mV below ground and 200mV above supply, allowing both ground and supply sensing.

The LMV7235 features an open drain output. By connecting an external resistor, the output of the comparator can be used as a level shifter.

The LMV7239/LMV7239Q features a push-pull output stage. This feature allows operation without the need of an external pull-up resistor.

The LMV7235/LMV7239/LMV7239Q are available in the 5-Pin SC70 and 5-Pin SOT-23 packages, which are ideal for systems where small size and low power is critical.



Please be aware that an important notice concerning availability, standard warranty, and use in critical applications of Texas Instruments semiconductor products and disclaimers thereto appears at the end of this data sheet.

All trademarks are the property of their respective owners.

PRODUCTION DATA information is current as of publication date. Products conform to specifications per the terms of the Texas Instruments standard warranty. Production processing does not necessarily include testing of all parameters.

Copyright © 2000–2013, Texas Instruments Incorporated

Typical Application

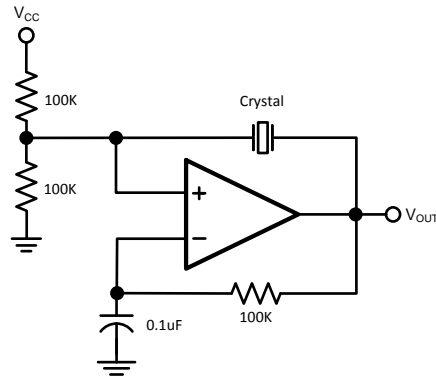

Figure 1. Crystal Oscillator

Connection Diagram

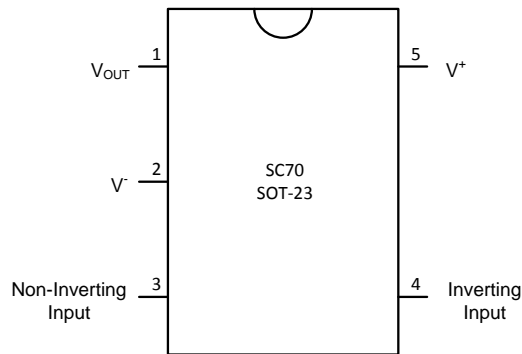
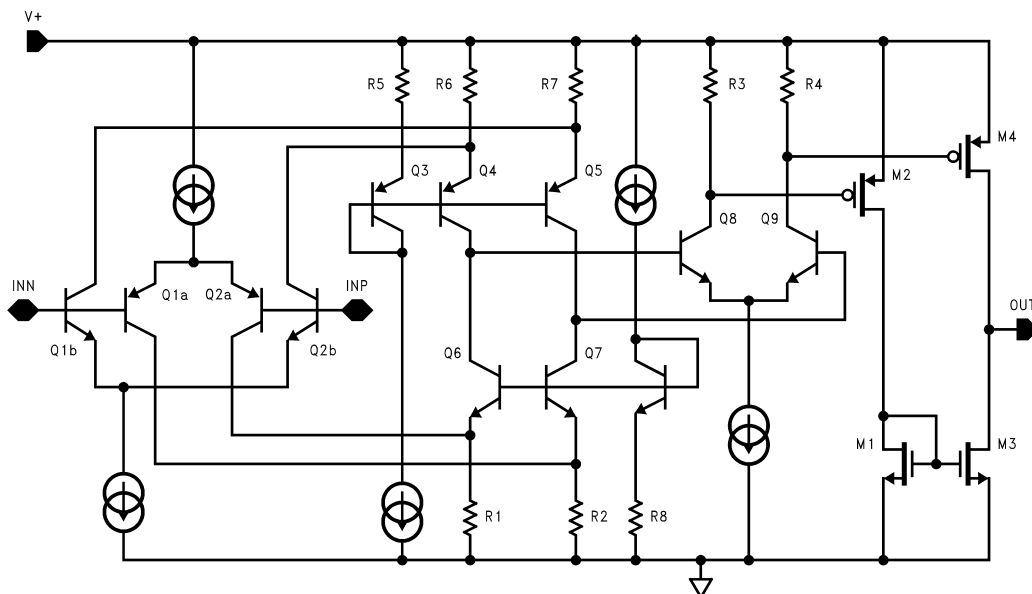

Figure 2. 5-Pin SC70/SOT-23 (Top View)

Simplified Schematic





These devices have limited built-in ESD protection. The leads should be shorted together or the device placed in conductive foam during storage or handling to prevent electrostatic damage to the MOS gates.

Absolute Maximum Ratings ⁽¹⁾⁽²⁾

ESD Tolerance ⁽³⁾	
Human Model Body	1000V
Machine Body	100V
Differential Input Voltage	± Supply Voltage
Output Short Circuit Duration	⁽⁴⁾
Supply Voltage ($V^+ - V^-$)	6V
Soldering Information	
Infrared or Convection (20 sec)	235°C
Wave Soldering (10 sec)	260°C (lead temp)
Voltage at Input/Output Pins	(V^+) +0.3V, (V^-) -0.3V
Current at Input Pin ⁽⁵⁾	±10mA

- (1) *Absolute Maximum Ratings* indicate limits beyond which damage to the device may occur. *Operating Ratings* indicate conditions for which the device is intended to be functional, but specific performance is not guaranteed. For guaranteed specifications and the test conditions, see the *Electrical Characteristics*.
- (2) **If Military/Aerospace specified devices are required, please contact the Texas Instruments Sales Office / Distributors for availability and specifications.**
- (3) Human Body Model, applicable std. MIL-STD-883, Method 3015.7. Machine Model, applicable std. JESD22-A115-A (ESD MM std. of JEDEC) Field-Induced Charge-Device Model, applicable std. JESD22-C101-C (ESD FICDM std. of JEDEC).
- (4) Applies to both single-supply and split-supply operation. Continuous short circuit operation at elevated ambient temperature can result in exceeding the maximum allowed junction temperature of 150°C. Output currents in excess of ±30mA over long term may adversely affect reliability.
- (5) Limiting input pin current is only necessary for input voltages that exceed absolute maximum input voltage ratings.

Operating Ratings

Supply Voltages ($V^+ - V^-$)	2.7V to 5.5V
Temperature Range ⁽¹⁾	
LMV7235/LMV7239	-40°C to +85°C
LMV7239Q	-40°C to +125°C
Storage Temperature Range	-65°C to +150°C
Package Thermal Resistance	
5-Pin SC70	478°C/W
5-Pin SOT-23	265°C/W

- (1) The maximum power dissipation is a function of $T_{J(MAX)}$, θ_{JA} . The maximum allowable power dissipation at any ambient temperature is $P_D = (T_{J(MAX)} - T_A) / \theta_{JA}$. All numbers apply for packages soldered directly onto a PC Board.

2.7V Electrical Characteristics

Unless otherwise specified, all limits guaranteed for $T_A = 25^\circ\text{C}$, $V_{CM} = V^+/2$, $V^+ = 2.7\text{V}$, $V^- = 0\text{V}$. **Boldface** limits apply at the temperature extremes.

Symbol	Parameter	Conditions	Min ⁽¹⁾	Typ ⁽²⁾	Max ⁽¹⁾	Units
V_{OS}	Input Offset Voltage			0.8	6 8	mV
I_B	Input Bias Current			30	400 600	nA
I_{OS}	Input Offset Current			5	200 400	nA

- (1) All limits are guaranteed by testing or statistical analysis.
- (2) Typical values represent the most likely parametric norm as determined at the time of characterization. Actual typical values may vary over time and will also depend on the application and configuration. The typical values are not tested and are not guaranteed on shipped production material.

2.7V Electrical Characteristics (continued)

Unless otherwise specified, all limits guaranteed for $T_A = 25^\circ\text{C}$, $V_{\text{CM}} = V^+/2$, $V^+ = 2.7\text{V}$, $V^- = 0\text{V}$. **Boldface** limits apply at the temperature extremes.

Symbol	Parameter	Conditions	Min ⁽¹⁾	Typ ⁽²⁾	Max ⁽¹⁾	Units	
CMRR	Common Mode Rejection Ratio	$0\text{V} < V_{\text{CM}} < 2.7\text{V}$ (3)	52	62		dB	
PSRR	Power Supply Rejection Ratio	$V^+ = 2.7\text{V}$ to 5V	65	85		dB	
V_{CM}	Input Common-Mode Voltage Range	CMRR > 50dB	$V^- - 0.1\text{V}^-$	-0.2 to 2.9	$V^+ + 0.1\text{V}^+$	V	
V_{O}	Output Swing High (LMV7239 only)	$I_{\text{L}} = 4\text{mA}$, $V_{\text{ID}} = 500\text{mV}$	$V^+ - 0.35$	$V^+ - 0.26$		V	
		$I_{\text{L}} = 0.4\text{mA}$, $V_{\text{ID}} = 500\text{mV}$		$V^+ - 0.02$		V	
	Output Swing Low (LMV7235/LMV7239/LMV7239Q)	$I_{\text{L}} = -4\text{mA}$, $V_{\text{ID}} = -500\text{mV}$		230	350 450		mV
		$I_{\text{L}} = -0.4\text{mA}$, $V_{\text{ID}} = -500\text{mV}$		15			mV
I_{SC}	Output Short Circuit Current	Sourcing, $V_{\text{O}} = 0\text{V}$ (LMV7239 only) (4)		15		mA	
		Sinking, $V_{\text{O}} = 2.7\text{V}$ (LMV7235, $R_{\text{L}} = 10\text{k}$) (4)		20		mA	
I_{S}	Supply Current	No load		52	85 100	μA	
t_{PD}	Propagation Delay	Overdrive = 20mV $C_{\text{LOAD}} = 15\text{pF}$ (5)		96		ns	
		Overdrive = 50mV $C_{\text{LOAD}} = 15\text{pF}$ (5)		87		ns	
		Overdrive = 100mV $C_{\text{LOAD}} = 15\text{pF}$ (5)		85		ns	
t_{SKEW}	Propagation Delay Skew (LMV7239 only)	Overdrive = 20mV (6)		2		ns	
t_{r}	Output Rise Time	LMV7239/LMV7239Q 10% to 90%		1.7		ns	
		LMV7235 10% to 90% (5)		112		ns	
t_{f}	Output Fall Time	90% to 10%		1.7		ns	
I_{LEAKAGE}	Output Leakage Current (LMV7235 only)			3		nA	

(3) CMRR is not linear over the common mode range. Limits are guaranteed over the worst case from 0 to $V_{\text{CC}/2}$ or $V_{\text{CC}/2}$ to V_{CC} .

(4) Applies to both single-supply and split-supply operation. Continuous short circuit operation at elevated ambient temperature can result in exceeding the maximum allowed junction temperature of 150°C . Output currents in excess of $\pm 30\text{mA}$ over long term may adversely affect reliability.

(5) A 10k pull-up resistor was used when measuring the LMV7235. The rise time of the LMV7235 is a function of the R-C time constant.

(6) Propagation Delay Skew is defined as the absolute value of the difference between $t_{\text{PD LH}}$ and $t_{\text{PD HL}}$.

5V Electrical Characteristics

Unless otherwise specified, all limits guaranteed for $T_A = 25^\circ\text{C}$, $V_{CM} = V^+/2$, $V^+ = 5\text{V}$, $V^- = 0\text{V}$. **Boldface** limits apply at the temperature extremes.

Symbol	Parameter	Conditions	Min ⁽¹⁾	Typ ⁽²⁾	Limits ⁽¹⁾	Units	
V_{OS}	Input Offset Voltage			1	6 8	mV	
I_B	Input Bias Current			30	400 600	nA	
I_{OS}	Input Offset Current			5	200 400	nA	
CMRR	Common Mode Rejection Ratio	$0\text{V} < V_{CM} < 5\text{V}$	52	67		dB	
PSRR	Power Supply Rejection Ratio	$V^+ = 2.7\text{V}$ to 5V	65	85		dB	
V_{CM}	Input Common-Mode Voltage Range	CMRR > 50dB	$V^- - 0.1\text{V}^-$	-0.2 to 5.2	$V^+ + 0.1\text{V}^+$	V	
V_O	Output Swing High (LMV7239 only)	$I_L = 4\text{mA}$, $V_{ID} = 500\text{mV}$	$V^+ - 0.25$	$V^+ - 0.15$		V	
		$I_L = 0.4\text{mA}$, $V_{ID} = 500\text{mV}$		$V^+ - 0.01$		V	
	Output Swing Low (LMV7235/LMV7239/LMV7239Q)	$I_L = -4\text{mA}$, $V_{ID} = -500\text{mV}$		230	350 450		mV
		$I_L = -0.4\text{mA}$, $V_{ID} = -500\text{mV}$		10			mV
I_{SC}	Output Short Circuit Current	Sourcing, $V_O = 0\text{V}$ (LMV7239 only) (3)	25 15	55		mA	
		Sinking, $V_O = 5\text{V}$ (LMV7235, $R_L = 10\text{k}$) (3)	30 20	60		mA	
I_S	Supply Current	No load		65	95 110	μA	
t_{PD}	Propagation Delay	Overdrive = 20mV $C_{LOAD} = 15\text{pF}$ (4)		89		ns	
		Overdrive = 50mV $C_{LOAD} = 15\text{pF}$ (4)		82		ns	
		Overdrive = 100mV $C_{LOAD} = 15\text{pF}$ (4)		75		ns	
t_{SKEW}	Propagation Delay Skew (LMV7239 only)	Overdrive = 20mV (5)		1		ns	
t_r	Output Rise Time	LMV7239 10% to 90%		1.2		ns	
		LMV7235 10% to 90% (4)		100		ns	
t_f	Output Fall Time	90% to 10%		1.2		ns	
$I_{LEAKAGE}$	Output Leakage Current (LMV7235 only)			3		nA	

- (1) All limits are guaranteed by testing or statistical analysis.
- (2) Typical values represent the most likely parametric norm as determined at the time of characterization. Actual typical values may vary over time and will also depend on the application and configuration. The typical values are not tested and are not guaranteed on shipped production material.
- (3) Applies to both single-supply and split-supply operation. Continuous short circuit operation at elevated ambient temperature can result in exceeding the maximum allowed junction temperature of 150°C . Output currents in excess of $\pm 30\text{mA}$ over long term may adversely affect reliability.
- (4) A 10k pull-up resistor was used when measuring the LMV7235. The rise time of the LMV7235 is a function of the R-C time constant.
- (5) Propagation Delay Skew is defined as the absolute value of the difference between t_{PDLH} and t_{PDHL} .

TYPICAL PERFORMANCE CHARACTERISTICS

(Unless otherwise specified, $V_S = 5V$, $C_L = 10pF$, $T_A = 25^\circ C$).

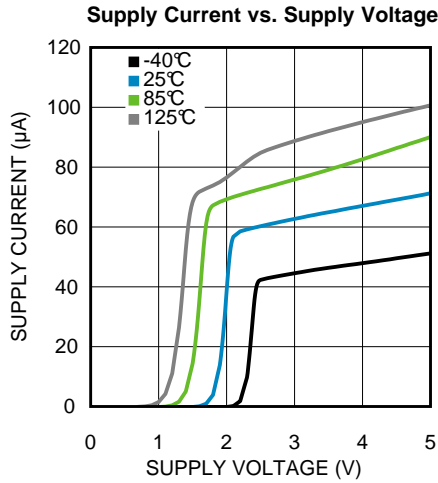

Figure 3.

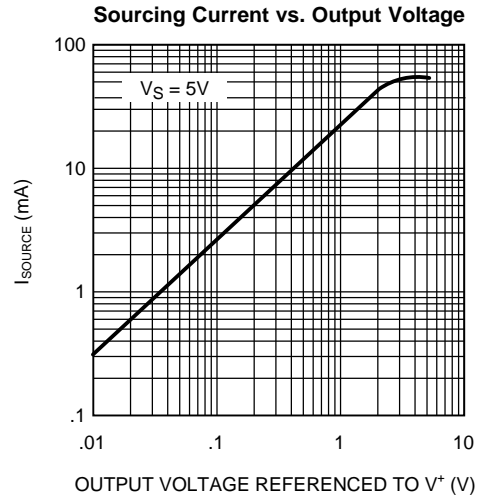

Figure 4.

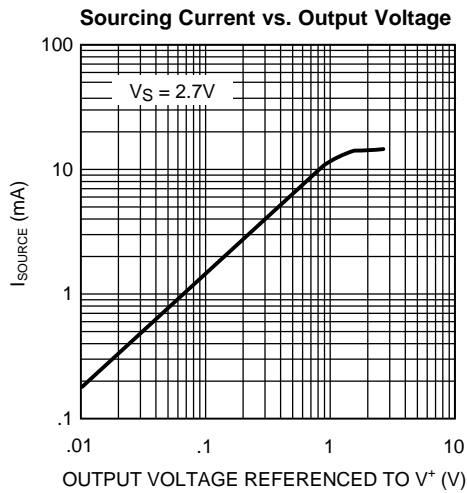

Figure 5.

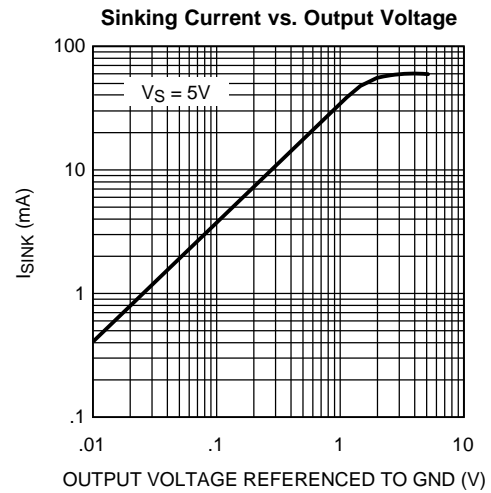

Figure 6.

TYPICAL PERFORMANCE CHARACTERISTICS (continued)

(Unless otherwise specified, $V_S = 5V$, $C_L = 10pF$, $T_A = 25^\circ C$).

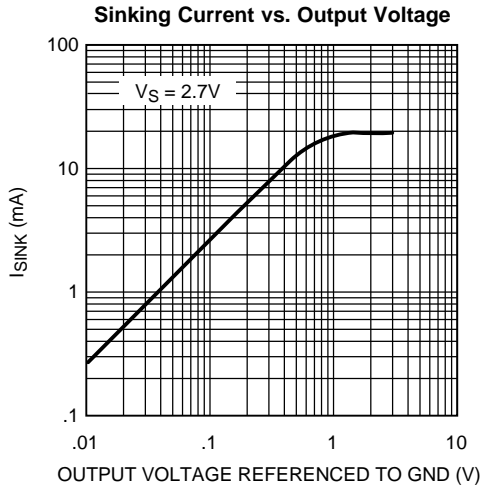

Figure 7.

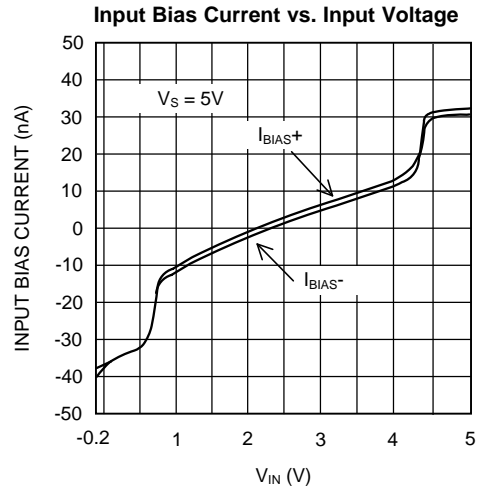

Figure 8.

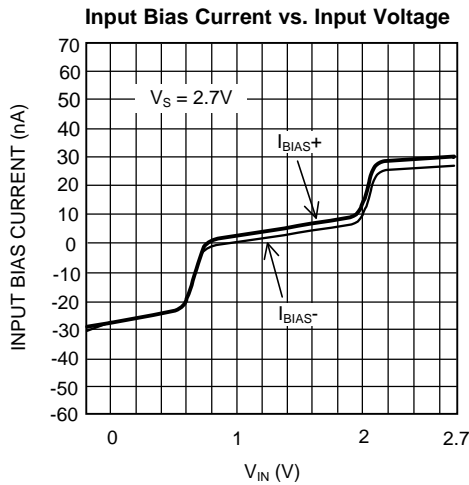

Figure 9.

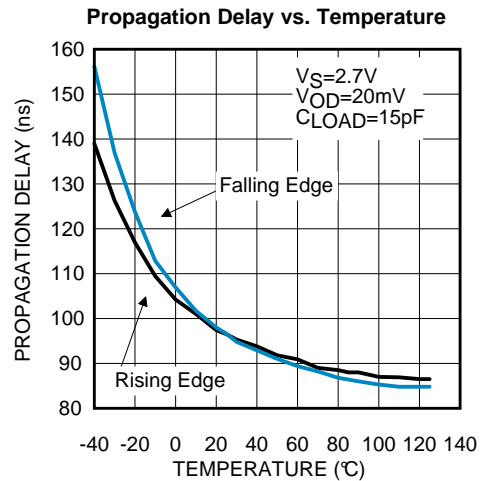

Figure 10.

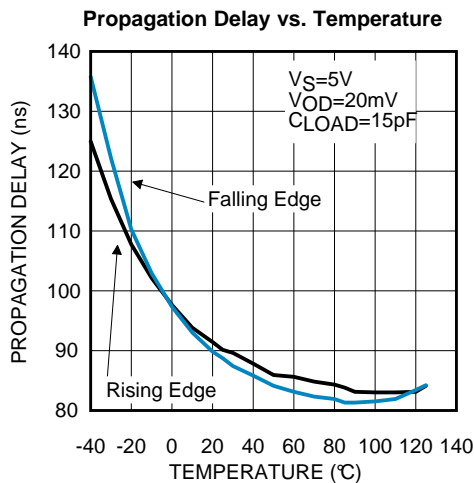

Figure 11.

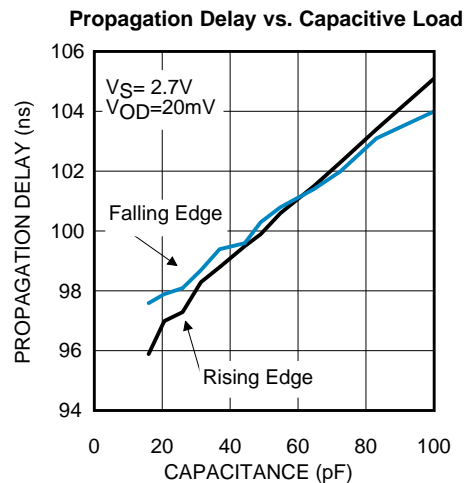

Figure 12.

TYPICAL PERFORMANCE CHARACTERISTICS (continued)

(Unless otherwise specified, $V_S = 5V$, $C_L = 10pF$, $T_A = 25^\circ C$).

Propagation Delay vs. Capacitive Load

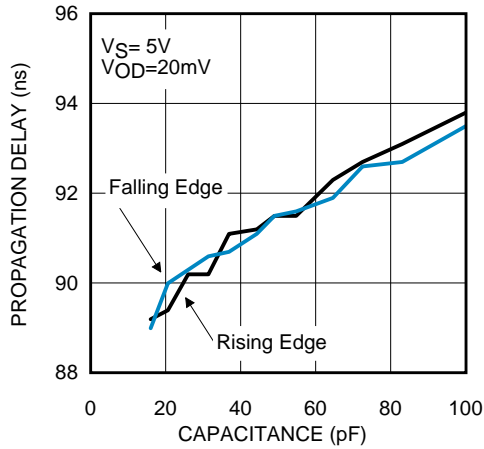

Figure 13.

Propagation Delay vs. Input Overdrive

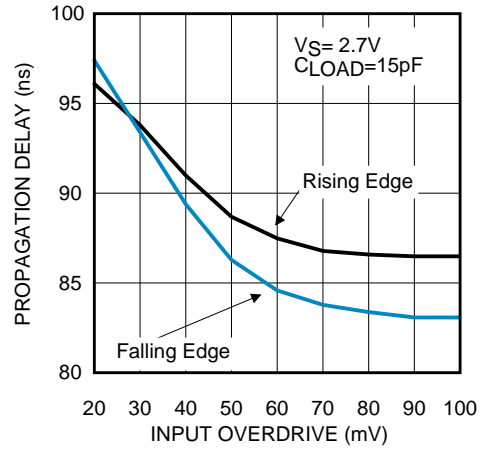

Figure 14.

Propagation Delay vs. Input Overdrive

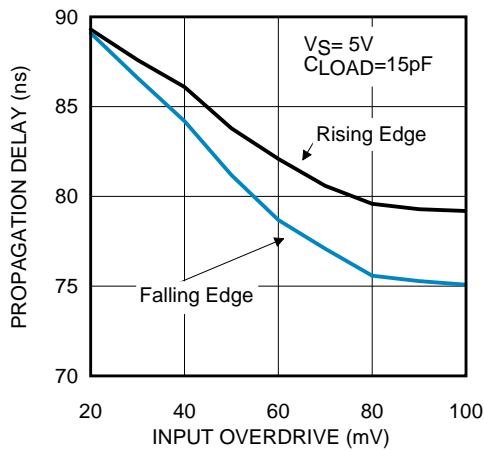

Figure 15.

Propagation Delay vs. Common Mode Voltage

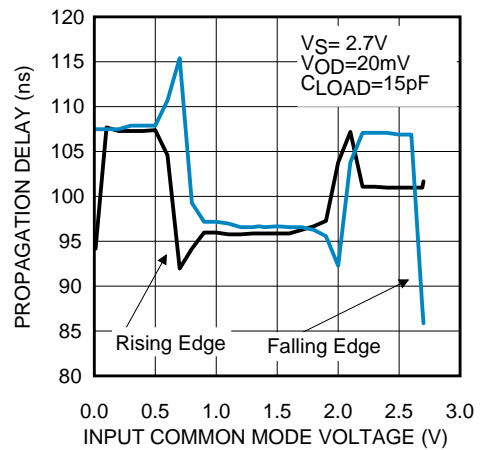

Figure 16.

Propagation Delay vs. Common Mode Voltage

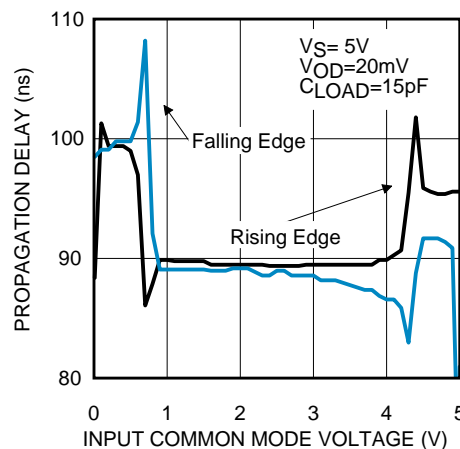

Figure 17.

APPLICATION INFORMATION

The LMV7235/LMV7239/LMV7239Q are single supply comparators with 75ns of propagation delay and only 65µA of supply current.

The LMV7235/LMV7239/LMV7239Q are rail-to-rail input and output. The typical input common mode voltage range of -0.2V below the ground to 0.2V above the supply. The LMV7235/LMV7239/LMV7239Q use a complimentary PNP and NPN input stage in which the PNP stage senses common mode voltage near V_- and the NPN stage senses common mode voltage near V^+ . If either of the input signals falls below the negative common mode limit, the parasitic PN junction formed by the substrate and the base of the PNP will turn on resulting in an increase of input bias current.

If one of the input goes above the positive common mode limit, the output will still maintain the correct logic level as long as the other input stays within the common mode range. However, the propagation delay will increase. When both inputs are outside the common mode voltage range, current saturation occurs in the input stage, and the output becomes unpredictable.

The propagation delay does not increase significantly with large differential input voltages. However, large differential voltages greater than the supply voltage should be avoided to prevent damage to the input stage.

The LMV7239 has a push-pull output. When the output switches, there is a direct path between V_{CC} and ground, causing high output sinking or sourcing current during the transition. After the transition, the output current decreases and the supply current settles back to about 65µA at 5V, thus conserving power consumption.

The LMV7235 has an open drain that requires a pull-up resistor to a positive supply voltage for the output to switch properly. When the internal output transistor is off, the output voltage will be pulled up to the external positive voltage.

CIRCUIT LAYOUT AND BYPASSING

The LMV7235/LMV7239/LMV7239Q require high speed layout. Follow these layout guidelines:

1. Use printed circuit board with a good, unbroken low-inductance ground plane.
2. Place a decoupling capacitor (0.1µF ceramic surface mount capacitor) as close as possible to V_{CC} pin.
3. On the inputs and the output, keep lead lengths as short as possible to avoid unwanted parasitic feedback around the comparator. Keep inputs away from output.
4. Solder the device directly to the printed circuit board rather than using a socket.
5. For slow moving input signals, take care to prevent parasitic feedback. A small capacitor (1000pF or less) placed between the inputs can help eliminate oscillations in the transition region. This capacitor causes some degradation to t_{PD} when the source impedance is low.
6. The topside ground plane runs between the output and inputs.
7. Ground trace from the ground pin runs under the device up to the bypass capacitor, shielding the inputs from the outputs.

COMPARATOR WITH HYSTERESIS

The basic comparator configuration may oscillate or produce a noisy output if the applied differential input voltage is near the comparator's offset voltage. This usually happens when the input signal is moving very slowly across the comparator's switching threshold. This problem can be prevented by the addition of hysteresis or positive feedback.

INVERTING COMPARATOR WITH HYSTERESIS

The inverting comparator with hysteresis requires a three resistor network that is referenced to the supply voltage V_{CC} of the comparator, as shown in [Figure 18](#). When V_{IN} at the inverting input is less than V_A , the voltage at the non-inverting node of the comparator ($V_{IN} < V_A$), the output voltage is high (for simplicity assume V_O switches as high as V_{CC}). The three network resistors can be represented as $R1||R3$ in series with $R2$. The lower input trip voltage V_{A1} is defined as:

$$V_{A1} = V_{CC}R2 / [(R1||R3) + R2] \quad (1)$$

When V_{IN} is greater than V_A ($V_{IN} > V_A$), the output voltage is low, very close to ground. In this case the three network resistors can be presented as $R2 \parallel R3$ in series with $R1$. The upper trip voltage V_{A2} is defined as:

$$V_{A2} = V_{CC} (R2 \parallel R3) / [(R1) + (R2 \parallel R3)] \tag{2}$$

The total hysteresis provided by the network is defined as:

$$\Delta V_A = V_{A1} - V_{A2} \tag{3}$$

To assure that the comparator will always switch fully to V_{CC} and not be pulled down by the load the resistors, values should be chosen as follows:

$$R_{PULL-UP} \ll R_{LOAD} \tag{4}$$

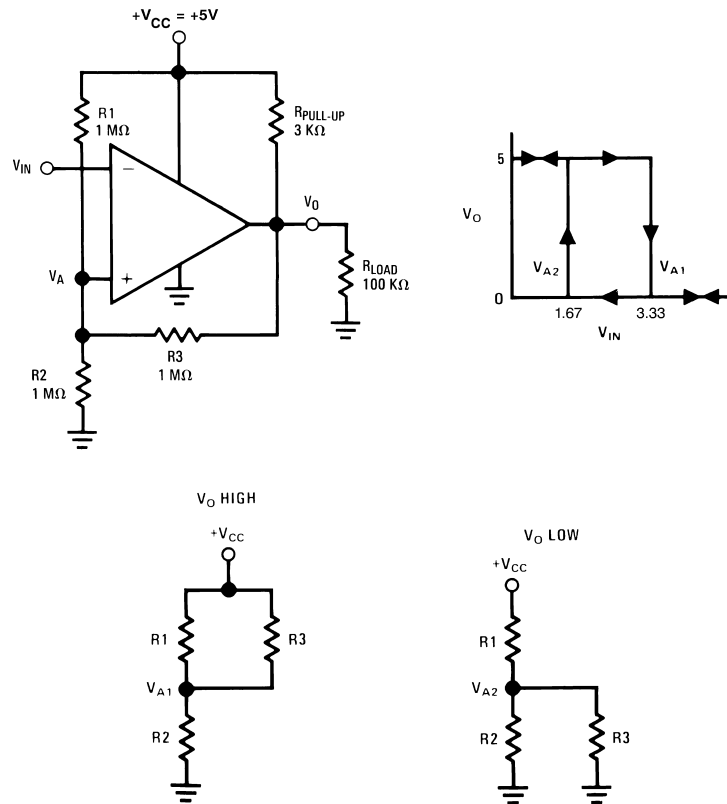

Figure 18. Inverting Comparator with Hysteresis

NON-INVERTING COMPARATOR WITH HYSTERESIS

A non inverting comparator with hysteresis requires a two resistor network, and a voltage reference (V_{REF}) at the inverting input. When V_{IN} is low, the output is also low. For the output to switch from low to high, V_{IN} must rise up to V_{IN1} where V_{IN1} is calculated by:

$$V_{IN1} = R1 * (V_{REF} / R2) + V_{REF} \tag{5}$$

When V_{IN} is high, the output is also high, to make the comparator switch back to its low state, V_{IN} must equal V_{REF} before V_A will again equal V_{REF} . V_{IN} can be calculated by:

$$V_{IN2} = [V_{REF} (R1 + R2) - V_{CC} R1] / R2 \tag{6}$$

The hysteresis of this circuit is the difference between V_{IN1} and V_{IN2} .

$$\Delta V_{IN} = V_{CC} R1 / R2 \tag{7}$$

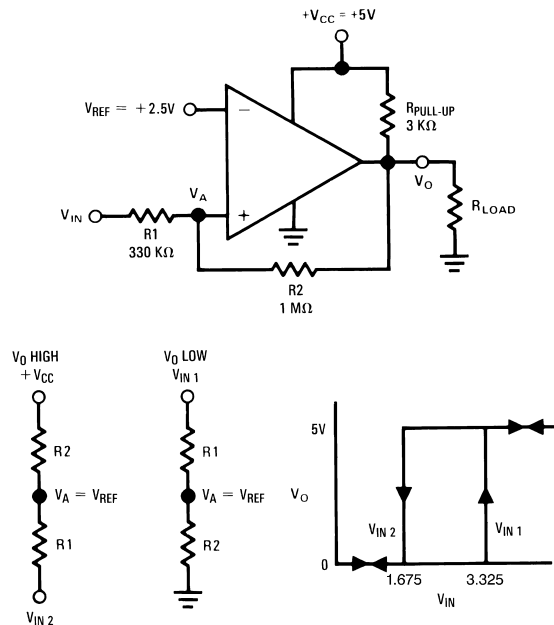

Figure 19. Non-Inverting Comparator with Hysteresis

ZERO-CROSSING DETECTOR

The inverting input is connected to ground and the non-inverting input is connected to 100mVp-p signal. As the signal at the non-inverting input crosses 0V, the comparator's output changes state.

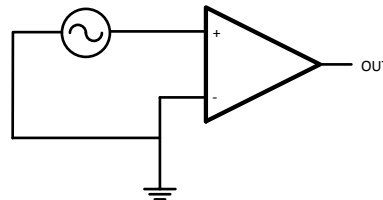

Figure 20. Zero-Crossing Detector

THRESHOLD DETECTOR

Instead of tying the inverting input to 0V, the inverting input can be tied to a reference voltage. The non-inverting input is connected to the input. As the input passes the V_{REF} threshold, the comparator's output changes state.

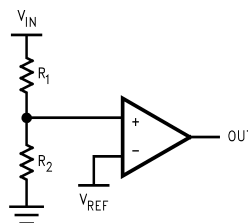

Figure 21. Threshold Detector

CRYSTAL OSCILLATOR

A simple crystal oscillator using the LMV7239 is shown below. Resistors R1 and R2 set the bias point at the comparator's non-inverting input. Resistors R3, R4 and C1 sets the inverting input node at an appropriate DC average level based on the output. The crystal's path provides resonant positive feedback and stable oscillation occurs. The output duty cycle for this circuit is roughly 50%, but it is affected by resistor tolerances and to a lesser extent by the comparator offset.

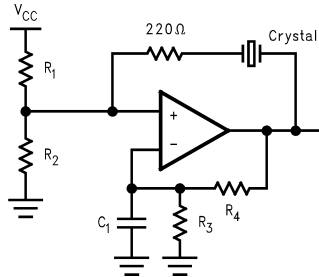

Figure 22. Crystal Oscillator

IR RECEIVER

The LMV7239 is an ideal candidate to be used as an infrared receiver. The infrared photo diode creates a current relative to the amount of infrared light present. The current creates a voltage across R_D . When this voltage level crosses the voltage applied by the voltage divider to the inverting input, the output transitions.

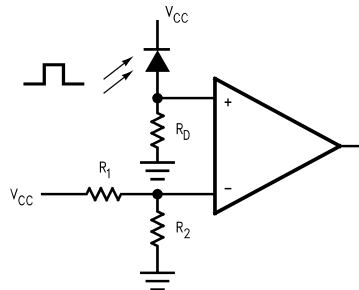

Figure 23. IR Receiver

REVISION HISTORY

Changes from Revision L (February 2013) to Revision M

Page

-
- Changed layout of National Data Sheet to TI format [12](#)
-

PACKAGING INFORMATION

Orderable Device	Status (1)	Package Type	Package Drawing	Pins	Package Qty	Eco Plan (2)	Lead/Ball Finish	MSL Peak Temp (3)	Op Temp (°C)	Top-Side Markings (4)	Samples
LMV7235M5	ACTIVE	SOT-23	DBV	5	1000	TBD	CU SNPB	Level-1-260C-UNLIM	-40 to 85	C21A	Samples
LMV7235M5/NOPB	ACTIVE	SOT-23	DBV	5	1000	Green (RoHS & no Sb/Br)	CU SN	Level-1-260C-UNLIM	-40 to 85	C21A	Samples
LMV7235M5X	ACTIVE	SOT-23	DBV	5	3000	TBD	CU SNPB	Level-1-260C-UNLIM	-40 to 85	C21A	Samples
LMV7235M5X/NOPB	ACTIVE	SOT-23	DBV	5	3000	Green (RoHS & no Sb/Br)	CU SN	Level-1-260C-UNLIM	-40 to 85	C21A	Samples
LMV7235M7	ACTIVE	SC70	DCK	5	1000	TBD	CU SNPB	Level-1-260C-UNLIM	-40 to 85	C21	Samples
LMV7235M7/NOPB	ACTIVE	SC70	DCK	5	1000	Green (RoHS & no Sb/Br)	CU SN	Level-1-260C-UNLIM	-40 to 85	C21	Samples
LMV7235M7X	ACTIVE	SC70	DCK	5	3000	TBD	CU SNPB	Level-1-260C-UNLIM	-40 to 85	C21	Samples
LMV7235M7X/NOPB	ACTIVE	SC70	DCK	5	3000	Green (RoHS & no Sb/Br)	CU SN	Level-1-260C-UNLIM	-40 to 85	C21	Samples
LMV7239M5	ACTIVE	SOT-23	DBV	5	1000	TBD	CU SNPB	Level-1-260C-UNLIM	-40 to 85	C20A	Samples
LMV7239M5/NOPB	ACTIVE	SOT-23	DBV	5	1000	Green (RoHS & no Sb/Br)	CU SN	Level-1-260C-UNLIM	-40 to 85	C20A	Samples
LMV7239M5X	ACTIVE	SOT-23	DBV	5	3000	TBD	CU SNPB	Level-1-260C-UNLIM	-40 to 85	C20A	Samples
LMV7239M5X/NOPB	ACTIVE	SOT-23	DBV	5	3000	Green (RoHS & no Sb/Br)	CU SN	Level-1-260C-UNLIM	-40 to 85	C20A	Samples
LMV7239M7	ACTIVE	SC70	DCK	5	1000	TBD	CU SNPB	Level-1-260C-UNLIM	-40 to 85	C20	Samples
LMV7239M7/NOPB	ACTIVE	SC70	DCK	5	1000	Green (RoHS & no Sb/Br)	CU SN	Level-1-260C-UNLIM	-40 to 85	C20	Samples
LMV7239M7X	ACTIVE	SC70	DCK	5	3000	TBD	CU SNPB	Level-1-260C-UNLIM	-40 to 85	C20	Samples
LMV7239M7X/NOPB	ACTIVE	SC70	DCK	5	3000	Green (RoHS & no Sb/Br)	CU SN	Level-1-260C-UNLIM	-40 to 85	C20	Samples
LMV7239QM7/NOPB	ACTIVE	SC70	DCK	5	1000	Green (RoHS & no Sb/Br)	CU SN	Level-1-260C-UNLIM	-40 to 125	C42	Samples
LMV7239QM7X/NOPB	ACTIVE	SC70	DCK	5	3000	Green (RoHS & no Sb/Br)	CU SN	Level-1-260C-UNLIM	-40 to 125	C42	Samples

(1) The marketing status values are defined as follows:

ACTIVE: Product device recommended for new designs.

LIFEBUY: TI has announced that the device will be discontinued, and a lifetime-buy period is in effect.

NRND: Not recommended for new designs. Device is in production to support existing customers, but TI does not recommend using this part in a new design.

PREVIEW: Device has been announced but is not in production. Samples may or may not be available.

OBSOLETE: TI has discontinued the production of the device.

(2) Eco Plan - The planned eco-friendly classification: Pb-Free (RoHS), Pb-Free (RoHS Exempt), or Green (RoHS & no Sb/Br) - please check <http://www.ti.com/productcontent> for the latest availability information and additional product content details.

TBD: The Pb-Free/Green conversion plan has not been defined.

Pb-Free (RoHS): TI's terms "Lead-Free" or "Pb-Free" mean semiconductor products that are compatible with the current RoHS requirements for all 6 substances, including the requirement that lead not exceed 0.1% by weight in homogeneous materials. Where designed to be soldered at high temperatures, TI Pb-Free products are suitable for use in specified lead-free processes.

Pb-Free (RoHS Exempt): This component has a RoHS exemption for either 1) lead-based flip-chip solder bumps used between the die and package, or 2) lead-based die adhesive used between the die and leadframe. The component is otherwise considered Pb-Free (RoHS compatible) as defined above.

Green (RoHS & no Sb/Br): TI defines "Green" to mean Pb-Free (RoHS compatible), and free of Bromine (Br) and Antimony (Sb) based flame retardants (Br or Sb do not exceed 0.1% by weight in homogeneous material)

(3) MSL, Peak Temp. -- The Moisture Sensitivity Level rating according to the JEDEC industry standard classifications, and peak solder temperature.

(4) Only one of markings shown within the brackets will appear on the physical device.

Important Information and Disclaimer: The information provided on this page represents TI's knowledge and belief as of the date that it is provided. TI bases its knowledge and belief on information provided by third parties, and makes no representation or warranty as to the accuracy of such information. Efforts are underway to better integrate information from third parties. TI has taken and continues to take reasonable steps to provide representative and accurate information but may not have conducted destructive testing or chemical analysis on incoming materials and chemicals. TI and TI suppliers consider certain information to be proprietary, and thus CAS numbers and other limited information may not be available for release.

In no event shall TI's liability arising out of such information exceed the total purchase price of the TI part(s) at issue in this document sold by TI to Customer on an annual basis.

OTHER QUALIFIED VERSIONS OF LMV7239, LMV7239-Q1 :

● Catalog: [LMV7239](#)

● Automotive: [LMV7239-Q1](#)

NOTE: Qualified Version Definitions:

● Catalog - TI's standard catalog product

● Automotive - Q100 devices qualified for high-reliability automotive applications targeting zero defects

TAPE AND REEL INFORMATION

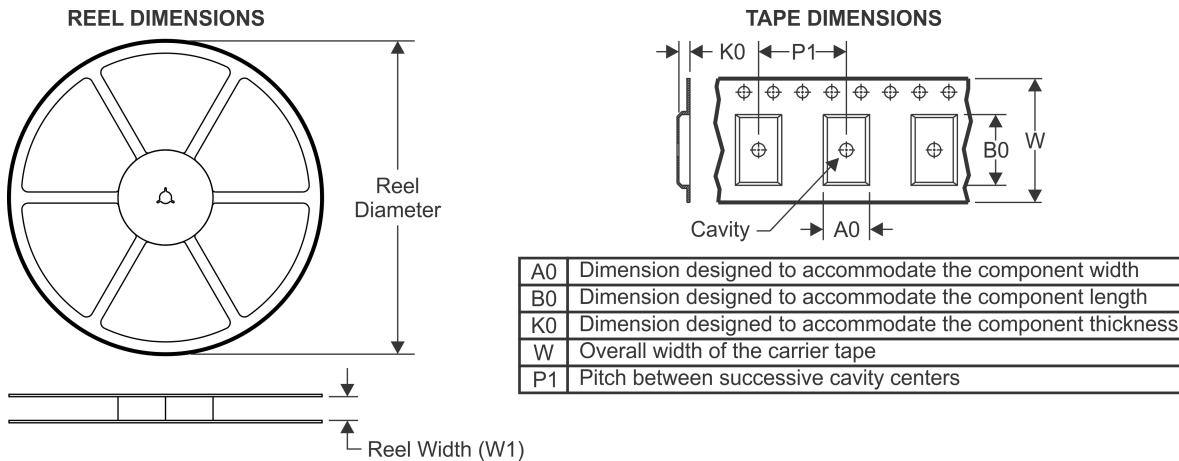

QUADRANT ASSIGNMENTS FOR PIN 1 ORIENTATION IN TAPE



*All dimensions are nominal

Device	Package Type	Package Drawing	Pins	SPQ	Reel Diameter (mm)	Reel Width W1 (mm)	A0 (mm)	B0 (mm)	K0 (mm)	P1 (mm)	W (mm)	Pin1 Quadrant
LMV7235M5	SOT-23	DBV	5	1000	178.0	8.4	3.2	3.2	1.4	4.0	8.0	Q3
LMV7235M5/NOPB	SOT-23	DBV	5	1000	178.0	8.4	3.2	3.2	1.4	4.0	8.0	Q3
LMV7235M5X	SOT-23	DBV	5	3000	178.0	8.4	3.2	3.2	1.4	4.0	8.0	Q3
LMV7235M5X/NOPB	SOT-23	DBV	5	3000	178.0	8.4	3.2	3.2	1.4	4.0	8.0	Q3
LMV7235M7	SC70	DCK	5	1000	178.0	8.4	2.25	2.45	1.2	4.0	8.0	Q3
LMV7235M7/NOPB	SC70	DCK	5	1000	178.0	8.4	2.25	2.45	1.2	4.0	8.0	Q3
LMV7235M7X	SC70	DCK	5	3000	178.0	8.4	2.25	2.45	1.2	4.0	8.0	Q3
LMV7235M7X/NOPB	SC70	DCK	5	3000	178.0	8.4	2.25	2.45	1.2	4.0	8.0	Q3
LMV7239M5	SOT-23	DBV	5	1000	178.0	8.4	3.2	3.2	1.4	4.0	8.0	Q3
LMV7239M5/NOPB	SOT-23	DBV	5	1000	178.0	8.4	3.2	3.2	1.4	4.0	8.0	Q3
LMV7239M5X	SOT-23	DBV	5	3000	178.0	8.4	3.2	3.2	1.4	4.0	8.0	Q3
LMV7239M5X/NOPB	SOT-23	DBV	5	3000	178.0	8.4	3.2	3.2	1.4	4.0	8.0	Q3
LMV7239M7	SC70	DCK	5	1000	178.0	8.4	2.25	2.45	1.2	4.0	8.0	Q3
LMV7239M7/NOPB	SC70	DCK	5	1000	178.0	8.4	2.25	2.45	1.2	4.0	8.0	Q3
LMV7239M7X	SC70	DCK	5	3000	178.0	8.4	2.25	2.45	1.2	4.0	8.0	Q3
LMV7239M7X/NOPB	SC70	DCK	5	3000	178.0	8.4	2.25	2.45	1.2	4.0	8.0	Q3
LMV7239QM7/NOPB	SC70	DCK	5	1000	178.0	8.4	2.25	2.45	1.2	4.0	8.0	Q3
LMV7239QM7X/NOPB	SC70	DCK	5	3000	178.0	8.4	2.25	2.45	1.2	4.0	8.0	Q3

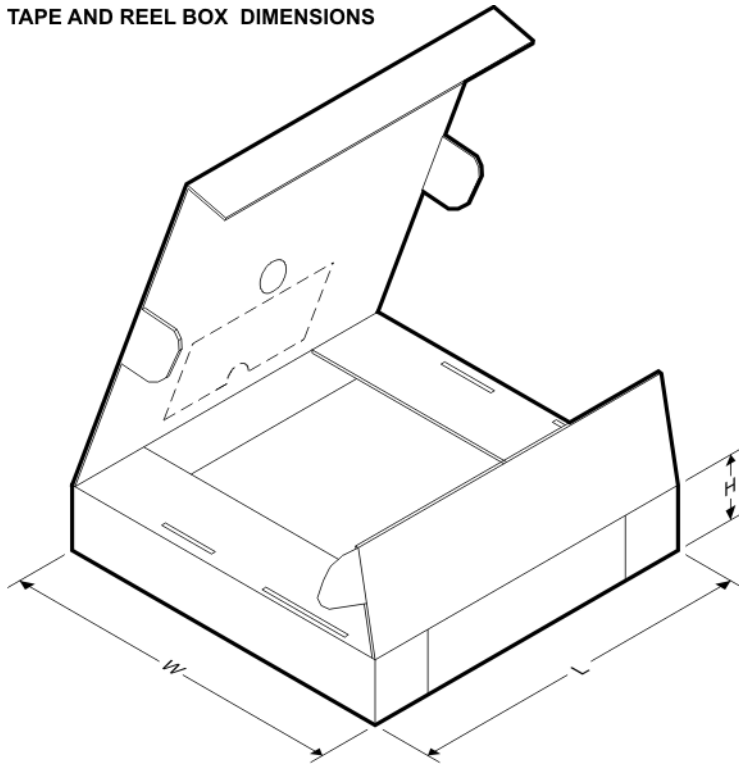
TAPE AND REEL BOX DIMENSIONS

*All dimensions are nominal

Device	Package Type	Package Drawing	Pins	SPQ	Length (mm)	Width (mm)	Height (mm)
LMV7235M5	SOT-23	DBV	5	1000	203.0	190.0	41.0
LMV7235M5/NOPB	SOT-23	DBV	5	1000	203.0	190.0	41.0
LMV7235M5X	SOT-23	DBV	5	3000	206.0	191.0	90.0
LMV7235M5X/NOPB	SOT-23	DBV	5	3000	206.0	191.0	90.0
LMV7235M7	SC70	DCK	5	1000	203.0	190.0	41.0
LMV7235M7/NOPB	SC70	DCK	5	1000	203.0	190.0	41.0
LMV7235M7X	SC70	DCK	5	3000	206.0	191.0	90.0
LMV7235M7X/NOPB	SC70	DCK	5	3000	206.0	191.0	90.0
LMV7239M5	SOT-23	DBV	5	1000	203.0	190.0	41.0
LMV7239M5/NOPB	SOT-23	DBV	5	1000	203.0	190.0	41.0
LMV7239M5X	SOT-23	DBV	5	3000	206.0	191.0	90.0
LMV7239M5X/NOPB	SOT-23	DBV	5	3000	206.0	191.0	90.0
LMV7239M7	SC70	DCK	5	1000	203.0	190.0	41.0
LMV7239M7/NOPB	SC70	DCK	5	1000	203.0	190.0	41.0
LMV7239M7X	SC70	DCK	5	3000	206.0	191.0	90.0
LMV7239M7X/NOPB	SC70	DCK	5	3000	206.0	191.0	90.0
LMV7239QM7/NOPB	SC70	DCK	5	1000	203.0	190.0	41.0
LMV7239QM7X/NOPB	SC70	DCK	5	3000	206.0	191.0	90.0

DBV (R-PDSO-G5)

PLASTIC SMALL-OUTLINE PACKAGE

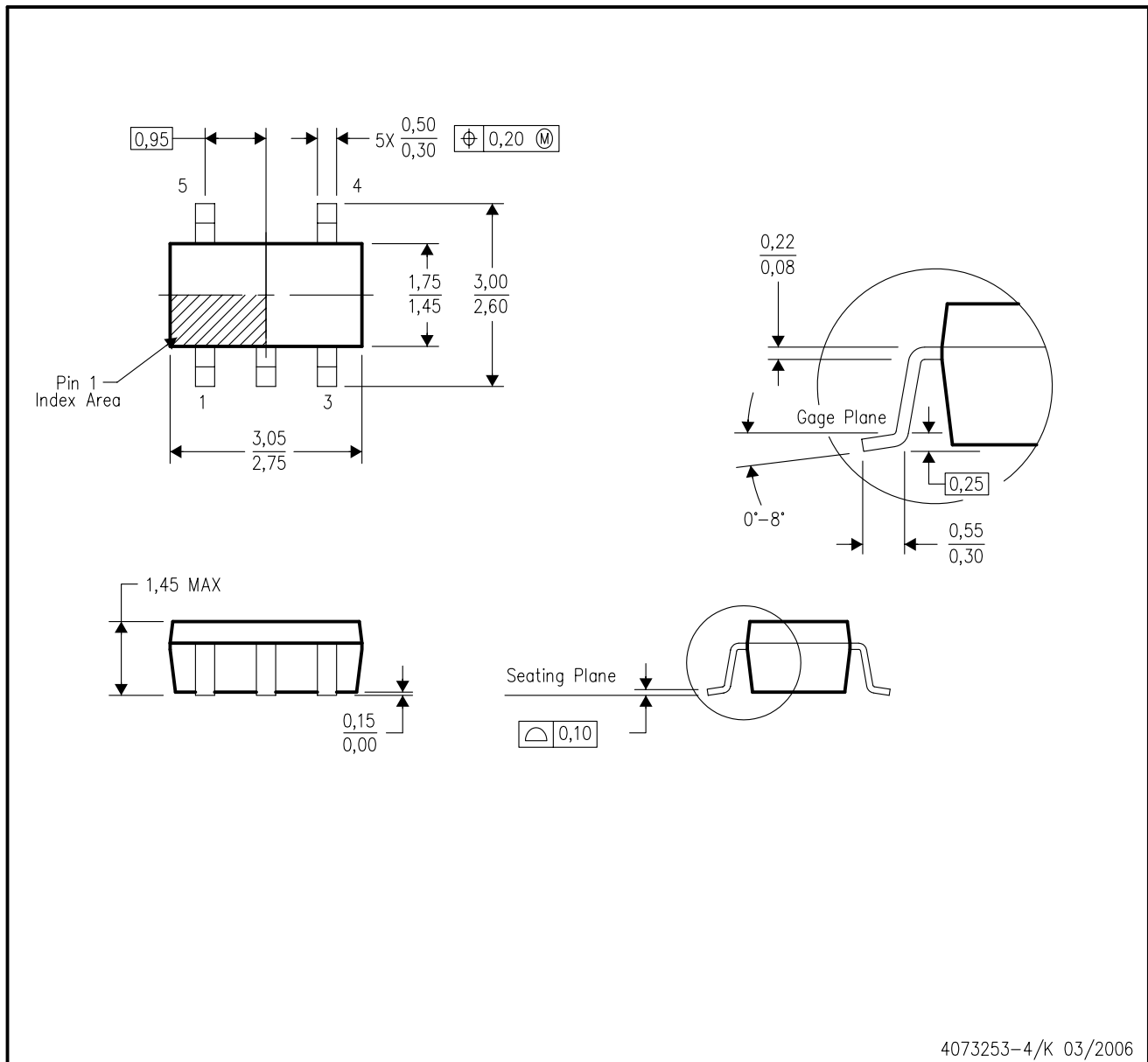

- NOTES:
- A. All linear dimensions are in millimeters.
 - B. This drawing is subject to change without notice.
 - C. Body dimensions do not include mold flash or protrusion. Mold flash and protrusion shall not exceed 0.15 per side.
 - D. Falls within JEDEC MO-178 Variation AA.

DBV (R-PDSO-G5)

PLASTIC SMALL OUTLINE



- NOTES:
- A. All linear dimensions are in millimeters.
 - B. This drawing is subject to change without notice.
 - C. Customers should place a note on the circuit board fabrication drawing not to alter the center solder mask defined pad.
 - D. Publication IPC-7351 is recommended for alternate designs.
 - E. Laser cutting apertures with trapezoidal walls and also rounding corners will offer better paste release. Customers should contact their board assembly site for stencil design recommendations. Example stencil design based on a 50% volumetric metal load solder paste. Refer to IPC-7525 for other stencil recommendations.

DCK (R-PDSO-G5)

PLASTIC SMALL-OUTLINE PACKAGE



- NOTES:
- A. All linear dimensions are in millimeters.
 - B. This drawing is subject to change without notice.
 - C. Body dimensions do not include mold flash or protrusion. Mold flash and protrusion shall not exceed 0.15 per side.
 - D. Falls within JEDEC MO-203 variation AA.

IMPORTANT NOTICE

Texas Instruments Incorporated and its subsidiaries (TI) reserve the right to make corrections, enhancements, improvements and other changes to its semiconductor products and services per JESD46, latest issue, and to discontinue any product or service per JESD48, latest issue. Buyers should obtain the latest relevant information before placing orders and should verify that such information is current and complete. All semiconductor products (also referred to herein as "components") are sold subject to TI's terms and conditions of sale supplied at the time of order acknowledgment.

TI warrants performance of its components to the specifications applicable at the time of sale, in accordance with the warranty in TI's terms and conditions of sale of semiconductor products. Testing and other quality control techniques are used to the extent TI deems necessary to support this warranty. Except where mandated by applicable law, testing of all parameters of each component is not necessarily performed.

TI assumes no liability for applications assistance or the design of Buyers' products. Buyers are responsible for their products and applications using TI components. To minimize the risks associated with Buyers' products and applications, Buyers should provide adequate design and operating safeguards.

TI does not warrant or represent that any license, either express or implied, is granted under any patent right, copyright, mask work right, or other intellectual property right relating to any combination, machine, or process in which TI components or services are used. Information published by TI regarding third-party products or services does not constitute a license to use such products or services or a warranty or endorsement thereof. Use of such information may require a license from a third party under the patents or other intellectual property of the third party, or a license from TI under the patents or other intellectual property of TI.

Reproduction of significant portions of TI information in TI data books or data sheets is permissible only if reproduction is without alteration and is accompanied by all associated warranties, conditions, limitations, and notices. TI is not responsible or liable for such altered documentation. Information of third parties may be subject to additional restrictions.

Resale of TI components or services with statements different from or beyond the parameters stated by TI for that component or service voids all express and any implied warranties for the associated TI component or service and is an unfair and deceptive business practice. TI is not responsible or liable for any such statements.

Buyer acknowledges and agrees that it is solely responsible for compliance with all legal, regulatory and safety-related requirements concerning its products, and any use of TI components in its applications, notwithstanding any applications-related information or support that may be provided by TI. Buyer represents and agrees that it has all the necessary expertise to create and implement safeguards which anticipate dangerous consequences of failures, monitor failures and their consequences, lessen the likelihood of failures that might cause harm and take appropriate remedial actions. Buyer will fully indemnify TI and its representatives against any damages arising out of the use of any TI components in safety-critical applications.

In some cases, TI components may be promoted specifically to facilitate safety-related applications. With such components, TI's goal is to help enable customers to design and create their own end-product solutions that meet applicable functional safety standards and requirements. Nonetheless, such components are subject to these terms.

No TI components are authorized for use in FDA Class III (or similar life-critical medical equipment) unless authorized officers of the parties have executed a special agreement specifically governing such use.

Only those TI components which TI has specifically designated as military grade or "enhanced plastic" are designed and intended for use in military/aerospace applications or environments. Buyer acknowledges and agrees that any military or aerospace use of TI components which have **not** been so designated is solely at the Buyer's risk, and that Buyer is solely responsible for compliance with all legal and regulatory requirements in connection with such use.

TI has specifically designated certain components as meeting ISO/TS16949 requirements, mainly for automotive use. In any case of use of non-designated products, TI will not be responsible for any failure to meet ISO/TS16949.

Products

Audio	www.ti.com/audio
Amplifiers	amplifier.ti.com
Data Converters	dataconverter.ti.com
DLP® Products	www.dlp.com
DSP	dsp.ti.com
Clocks and Timers	www.ti.com/clocks
Interface	interface.ti.com
Logic	logic.ti.com
Power Mgmt	power.ti.com
Microcontrollers	microcontroller.ti.com
RFID	www.ti-rfid.com
OMAP Applications Processors	www.ti.com/omap
Wireless Connectivity	www.ti.com/wirelessconnectivity

Applications

Automotive and Transportation	www.ti.com/automotive
Communications and Telecom	www.ti.com/communications
Computers and Peripherals	www.ti.com/computers
Consumer Electronics	www.ti.com/consumer-apps
Energy and Lighting	www.ti.com/energy
Industrial	www.ti.com/industrial
Medical	www.ti.com/medical
Security	www.ti.com/security
Space, Avionics and Defense	www.ti.com/space-avionics-defense
Video and Imaging	www.ti.com/video

TI E2E Community

e2e.ti.com